

MaxMotion

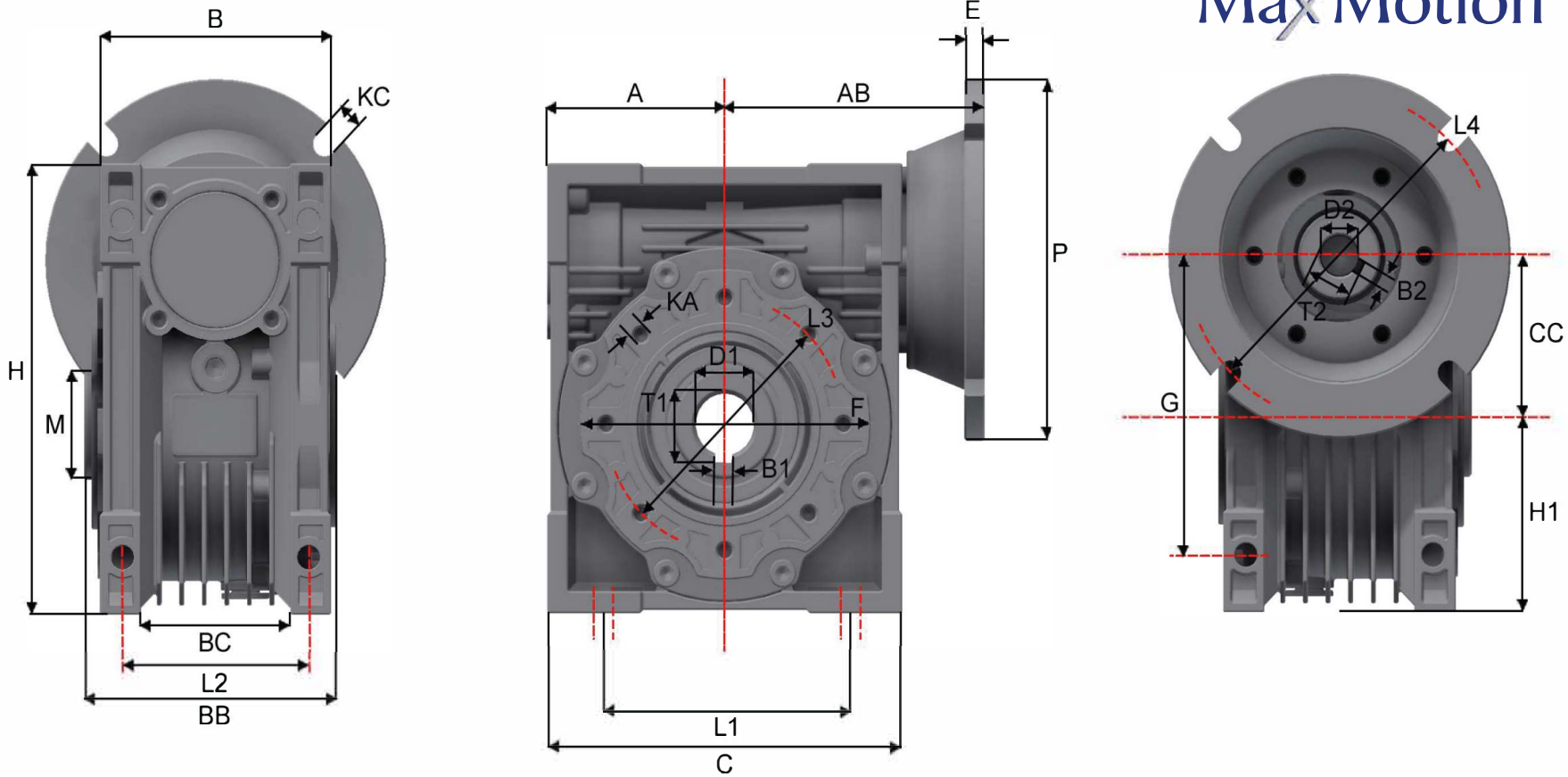

Version: 1HAN		Revised: 01-05-2020		Worm Gear Right 90° Angle Gearbox						MMR50-56C				
Customer is responsible in determining that MEP product will fit/perform suitably in the intended application														
A	B	C	E	F	G	H	M	P	B1	B2	D1	D2	H1	
60	87	121	5	100	90	144	70 +0.046	∅165	6.35 +0.018	4.76 +0.078/0.03	∅25.4 +0.033	15.87 +0.059/0.032	60	
L1	L2	L3	L4	T1	T2	AB	BB	BC	CC	KA	KC			
80	70	85	∅149.225+0.035	28.3 +0.2	18.3 +0.10/-0.0	90	92	49	50	M8 X 10	R5.5			

RIGHT ANGLE SPEED REDUCER

ALUMINUM CONSTRUCTION



DIMENSION DESIGNATIONS:

BACK VIEW	
H	Height of gearbox casing.
M	Outer diameter of output hollow shaft sleeve lip.
B	Width of gearbox casing
KC	Hole slot size in input flange for motor mounting.
BC	Inside distance between side mounting feet.
L2	Center distance between feet mounting holes.
BB	Width of gearbox casing + lip of hollow shaft sleeve seat.
SIDE VIEW	
A	Horizontal distance from the center of hollow output shaft to the side of the gearbox casing.
AB	Horizontal distance from the center of hollow output shaft to the outside of the front motor mounting input flange.
E	Input mounting flange thickness.
P	Outer diameter of input motor mounting flange.
L1	Center distance between feet mounting holes.
C	Width of gearbox casing.
KA	Hole size for mounting optional output flange or torque arm.
L3	Bolt circle for mounting optional output flange or torque arm.
F	External width of mounting provisions for optional output flange.
D1	Output shaft diameter.
B1	Width of the output shaft key.
T1	Hollow output shaft diameter + 1/2 key.
FRONT VIEW	
G	Center distance between hollow input shaft and side mounting holes.
L4	Bolt circle in input motor mounting flange.
CC	Center distance between input & output shafts. (Input & output gears).
H1	Height to the center of the output shaft.
D2	Input shaft diameter.
B2	Width of the input shaft key.
T2	Hollow input shaft diameter + 1/2 key.

MaxMotion

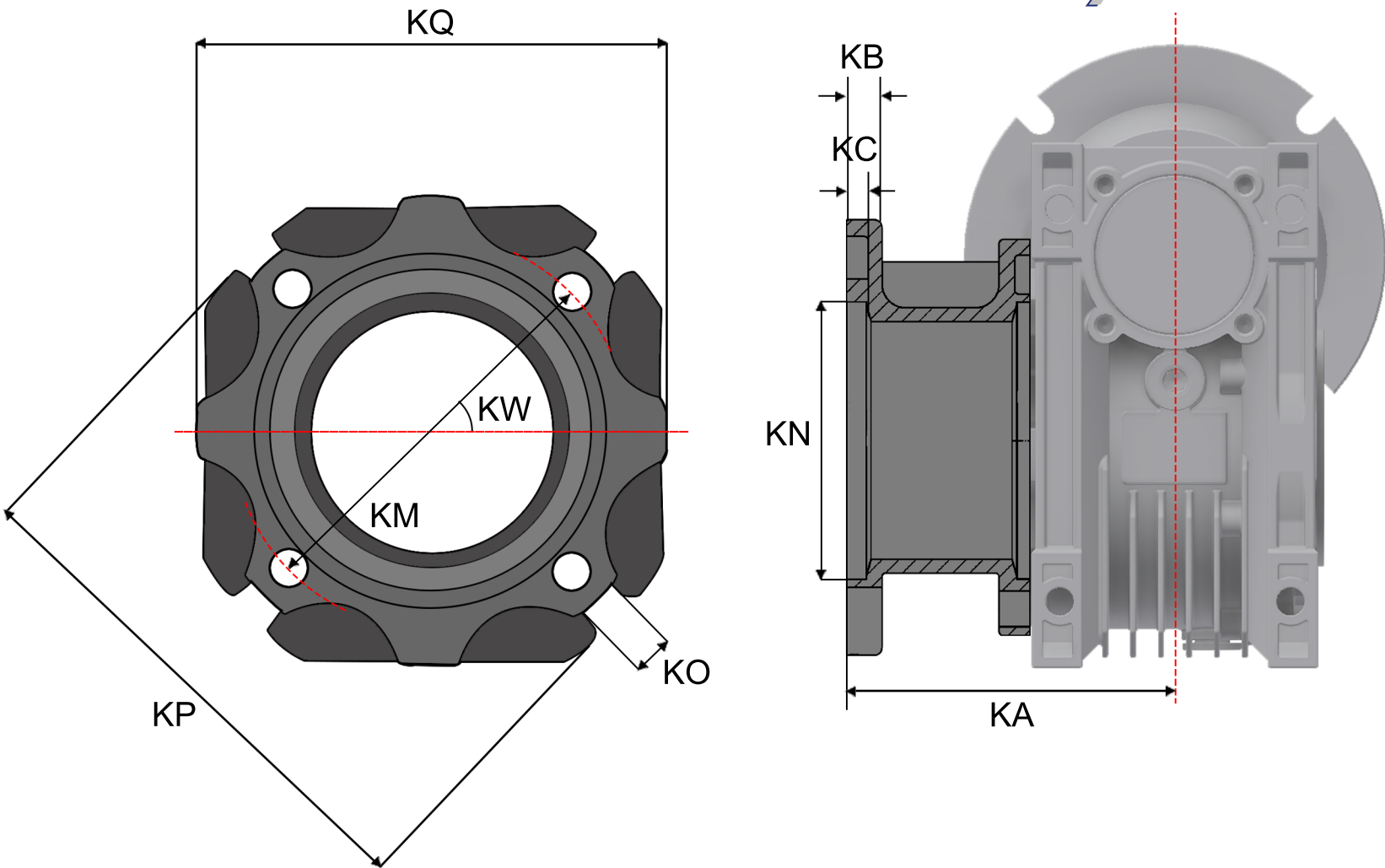

Customer is responsible in determining that MEP product will fit/perform suitably in the intended application

Version: 1HAN

Revised: 30-04-2020

SIZE	KA	KB	KC	KN	KM	KO	KP	KQ	KW
50	90	9	5	70	85	11(n°4)	125	110	45°

MMR50-FLANGE

MaxMotion

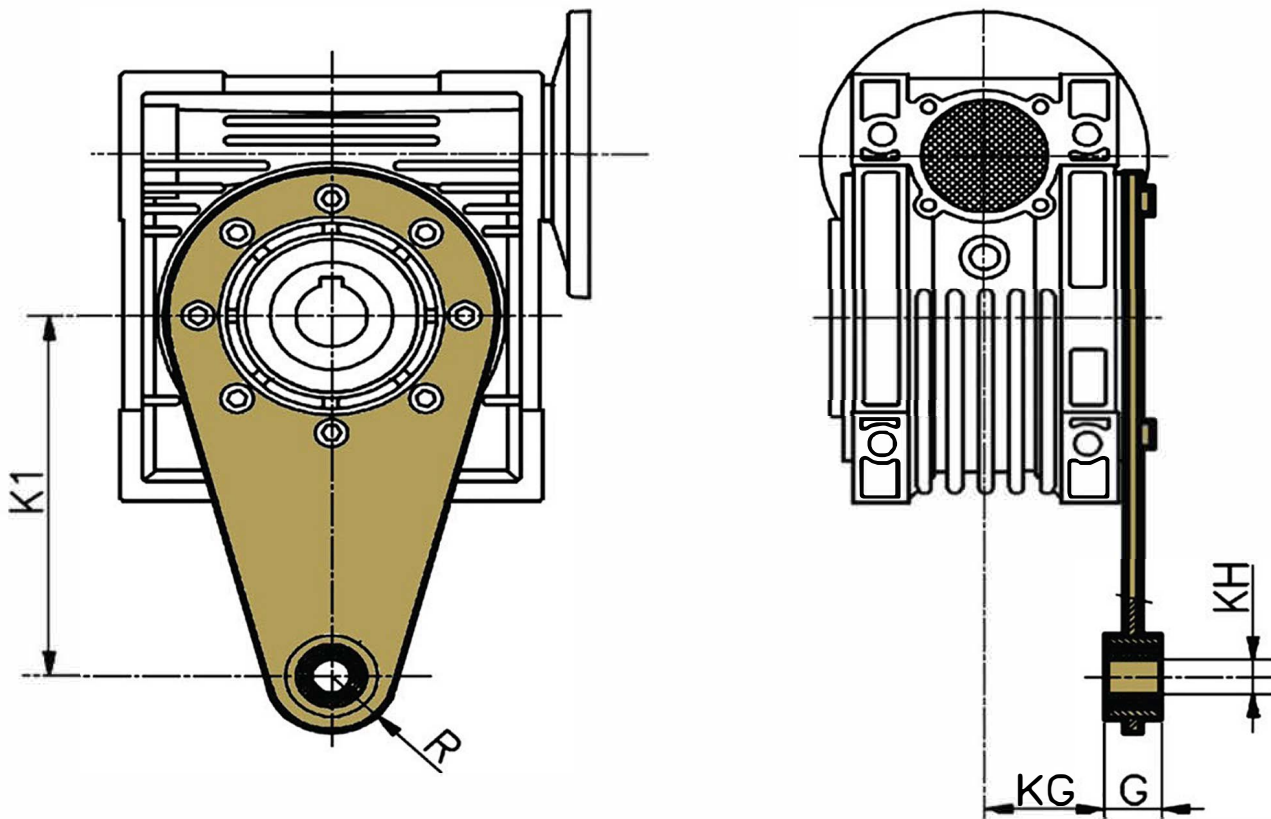

Customer is responsible in determining that MEP product will fit/perform suitably in the intended application

Version: 1HAN

Revised: 30-04-2020

SIZE	K1	G	KG	KH	R
50	100	14	38.5	10	18

MMR50-ARM

MaxMotion

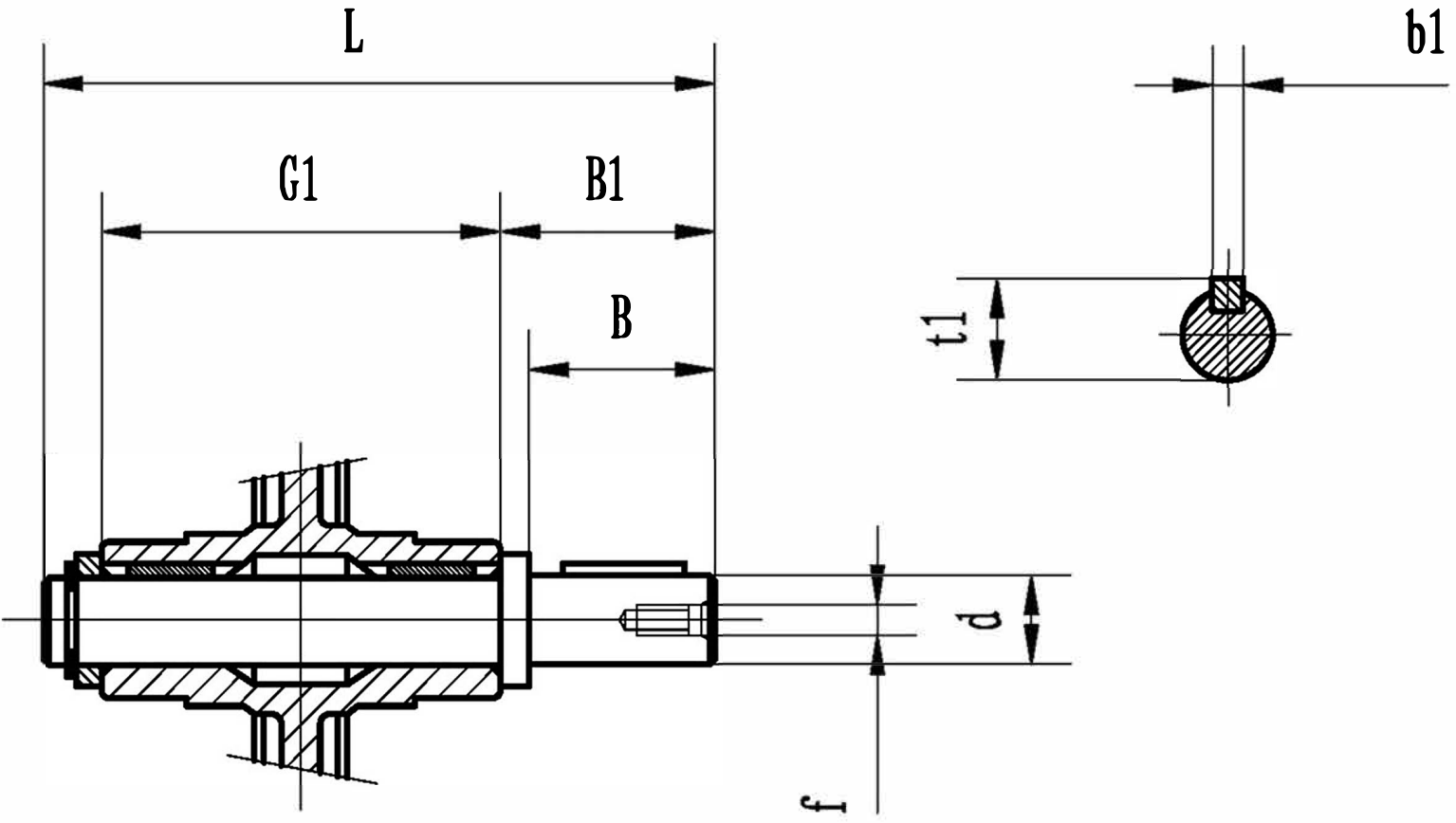

Customer is responsible in determining that MEP product will fit/perform suitably in the intended application

Version: 1HAN

Revised: 30-04-2020

SIZE	B	d	f	L	B1	b1	G1	t1
50	50	25h6	M10	153	53.5	8	92	28

MMR50-SINGLE OUTPUT SHAFT

MaxMotion

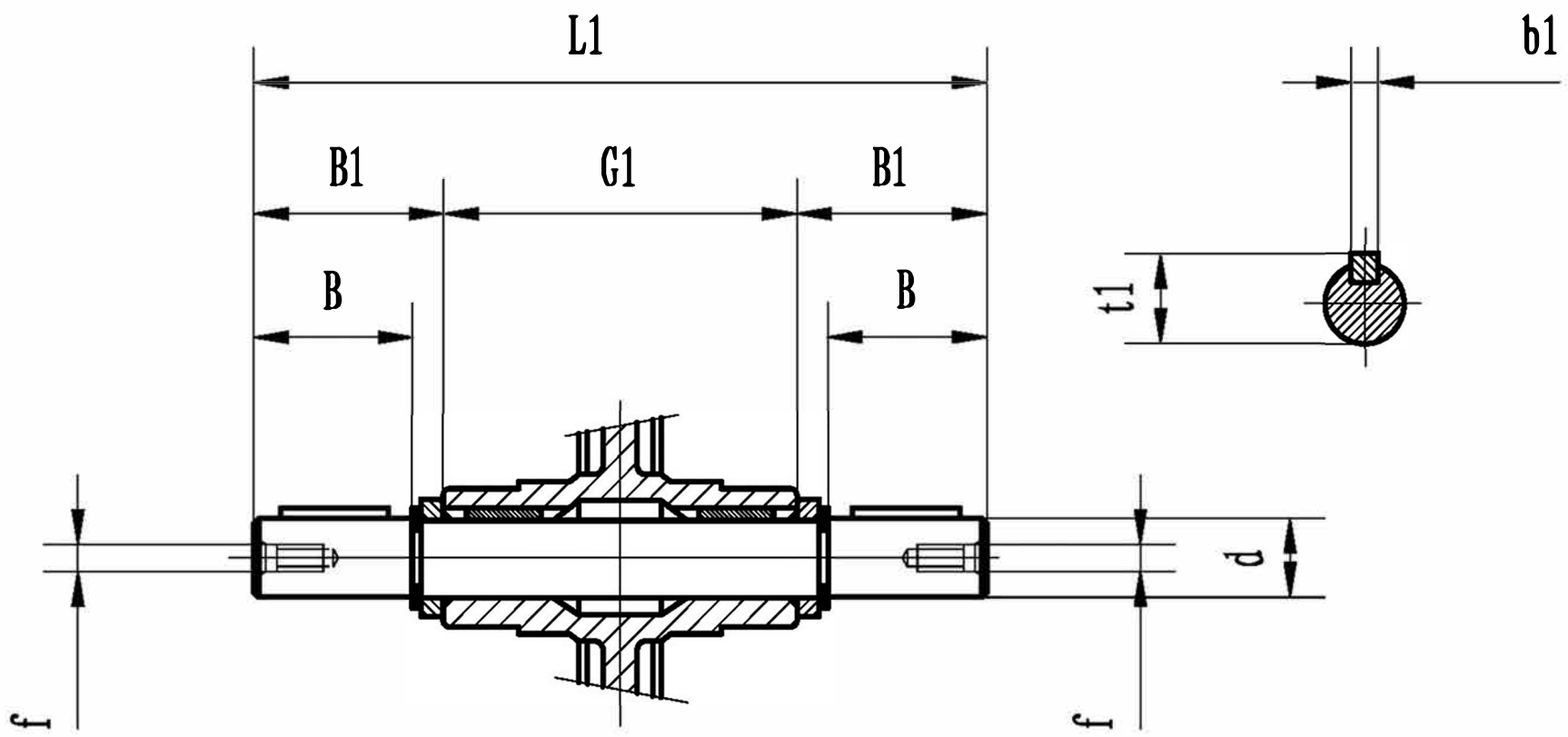

Customer is responsible in determining that MEP product will fit/perform suitably in the intended application

Version: 1HAN

Revised: 30-04-2020

SIZE	B	d	f	L1	B1	b1	G1	t1
50	50	25h6	M10	199	53.5	8	92	28

MMR50-DOUBLE OUTPUT SHAFT

RIGHT ANGLE SPEED REDUCER

ALUMINUM CONSTRUCTION

MaxMotion

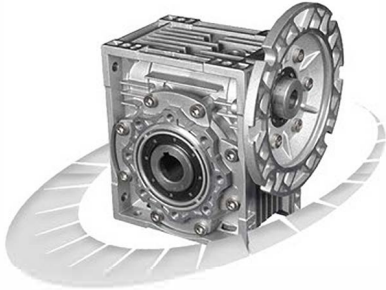

Features:

- Aluminum alloy Housing with heat sink design
- Two bearings on Input shaft
- NEMA 56C Input
- Double Lip Seals
- O Rings on input and output covers
- Hardened worm shaft
- Permanently sealed with Synthetic lubrication
- Warranty 1 year

Benefits:

- Resists wash down & has higher thermal capacity
- Allows true alignment & prevents oil leaks
- Allows use of standard NEMA motors
- Prevents leaks and avoids oil contamination
- Seals better than paper gaskets
- Increase durability over forged design
- Plug-in solid shafts for greater mounting flexibility
- Maintenance free, no breather or fill plugs

MOUNTING VERSIONS

Standard Hollow Shaft Reducer

- Mounting feet on 3 surfaces for universal mounting.
- Machined mounting faces on both output sides with tapped mounting holes.

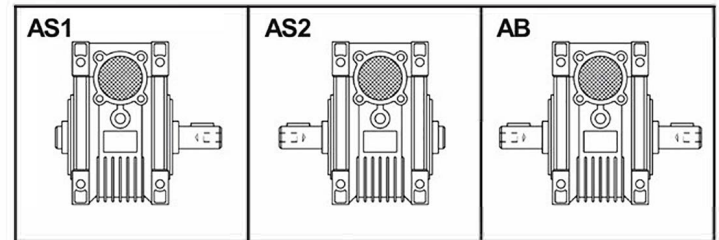

Solid Single & Double Output Shafts

- Plug into standard hollow shaft.
- Easy field installation.

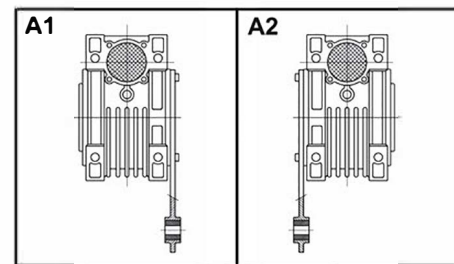

Bolt-On Torque Arm

- Bolts on to reducer machined face.
- C/W With flexible rubber bushing.

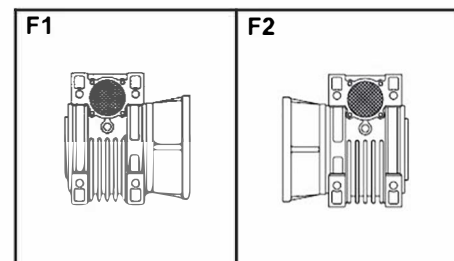

Bolt-On Output Flange Adaptor

- Bolts on to reducer machined face.
- Used with hollow or solid shaft.

RIGHT ANGLE SPEED REDUCER

ALUMINUM CONSTRUCTION



MODEL	RATIO	OUTPUT RPM	OUTPUT TORQUE IN LBS	MAX INPUT HP @1750RPM	MAX OHL LBS	BORE SIZE	SINGLE O.P SHAFT	DOUBLE O.P SHAFT	TORQUE ARM	OUTPUT FLANGE	SAFETY COVER
MMR50-5-56C	5	350	549	3.43	322	1.000"	MMR50-SS	MMR50-DS	MMR50-ARM	MMR50-FLANGE	MMR50-COVER
MMR50-7.5-56C	7.5	23	638	2.64	369	1.000"	MMR50-SS	MMR50-DS	MMR50-ARM	MMR50-FLANGE	MMR50-COVER
MMR50-10-56C	10	175	637	2.06	406	1.000"	MMR50-SS	MMR50-DS	MMR50-ARM	MMR50-FLANGE	MMR50-COVER
MMR50-15-56C	15	117	655	1.48	464	1.000"	MMR50-SS	MMR50-DS	MMR50-ARM	MMR50-FLANGE	MMR50-COVER
MMR50-20-56C	20	88	646	1.14	510	1.000"	MMR50-SS	MMR50-DS	MMR50-ARM	MMR50-FLANGE	MMR50-COVER
MMR50-25-56C	25	70	619	.90	551	1.000"	MMR50-SS	MMR50-DS	MMR50-ARM	MMR50-FLANGE	MMR50-COVER
MMR50-30-56C	30	58	743	.96	586	1.000"	MMR50-SS	MMR50-DS	MMR50-ARM	MMR50-FLANGE	MMR50-COVER
MMR50-40-56C	40	44	672	.70	643	1.000"	MMR50-SS	MMR50-DS	MMR50-ARM	MMR50-FLANGE	MMR50-COVER
MMR50-50-56C	50	35	646	.57	694	1.000"	MMR50-SS	MMR50-DS	MMR50-ARM	MMR50-FLANGE	MMR50-COVER
MMR50-60-56C	60	29	602	.47	739	1.000"	MMR50-SS	MMR50-DS	MMR50-ARM	MMR50-FLANGE	MMR50-COVER
MMR50-80-56C	80	22	575	.38	810	1.000"	MMR50-SS	MMR50-DS	MMR50-ARM	MMR50-FLANGE	MMR50-COVER
MMR50-100-56C	100	18	487	.28	866	1.000"	MMR50-SS	MMR50-DS	MMR50-ARM	MMR50-FLANGE	MMR50-COVER
MMR63-7.5-56C	7.5	233	1133	4.77	463	1.000"	MMR63-SS	MMR63-DS	MMR63-ARM	MMR63-FLANGE	MMR63-COVER
MMR63-10-56C	10	175	1150	3.67	510	1.000"	MMR63-SS	MMR63-DS	MMR63-ARM	MMR63-FLANGE	MMR63-COVER
MMR63-15-56C	15	117	1239	2.76	583	1.000"	MMR63-SS	MMR63-DS	MMR63-ARM	MMR63-FLANGE	MMR63-COVER
MMR63-20-56C	20	88	1194	2.05	641	1.000"	MMR63-SS	MMR63-DS	MMR63-ARM	MMR63-FLANGE	MMR63-COVER
MMR63-25-56C	25	70	1150	1.64	692	1.000"	MMR63-SS	MMR63-DS	MMR63-ARM	MMR63-FLANGE	MMR63-COVER
MMR63-30-56C	30	58	1416	1.77	736	1.000"	MMR63-SS	MMR63-DS	MMR63-ARM	MMR63-FLANGE	MMR63-COVER
MMR63-40-56C	40	44	1283	1.27	807	1.000"	MMR63-SS	MMR63-DS	MMR63-ARM	MMR63-FLANGE	MMR63-COVER
MMR63-50-56C	50	35	1194	1.01	871	1.000"	MMR63-SS	MMR63-DS	MMR63-ARM	MMR63-FLANGE	MMR63-COVER
MMR63-60-56C	60	29	1150	.86	928	1.000"	MMR63-SS	MMR63-DS	MMR63-ARM	MMR63-FLANGE	MMR63-COVER
MMR63-80-56C	80	22	1079	.66	1017	1.000"	MMR63-SS	MMR63-DS	MMR63-ARM	MMR63-FLANGE	MMR63-COVER
MMR63-100-56C	100	15	1044	.57	1088	1.000"	MMR63-SS	MMR63-DS	MMR63-ARM	MMR63-FLANGE	MMR63-COVER
MMR75-50-56C	50	35	1880	1.47	1093	1.250"	MMR75-SS	MMR75-DS	MMR75-ARM	MMR75-FLANGE	MMR75-COVER
MMR75-60-56C	60	29	1778	1.22	1162	1.250"	MMR75-SS	MMR75-DS	MMR75-ARM	MMR75-FLANGE	MMR75-COVER
MMR75-80-56C	80	22	1632	.91	1279	1.250"	MMR75-SS	MMR75-DS	MMR75-ARM	MMR75-FLANGE	MMR75-COVER
MMR75-100-56C	100	18	1517	.94	1378	1.250"	MMR75-SS	MMR75-DS	MMR75-ARM	MMR75-FLANGE	MMR75-COVER
MMR90-80-56C	80	22	2396	1.27	1415	1.375"	MMR90-SS	MMR90-DS	MMR90-ARM	MMR90-FLANGE	MMR90-COVER
MMR90-100-56C	100	18	2270	1.03	1524	1.375"	MMR90-SS	MMR90-DS	MMR90-ARM	MMR90-FLANGE	MMR90-COVER

Available Accesories:



Single output shaft



Double output shaft



Output Flange



Torque Arm



Safety Cover